

# Non-State Actors and Unmanned Aerial Vehicles

Presentation at ISODARCO XXVI Winter Course “New Military Technologies:  
Implications for Strategy and Arms Control, 6-13 January, 2013, Andalo, Italy

Eugene Miasnikov, Ph.D.  
Center for Arms Control, Energy & Environmental Studies  
Dolgoprudny, Moscow Region, Russia  
@EMiasnikov

[www.armscontrol.ru](http://www.armscontrol.ru)

# Unmanned aerial vehicles: background information

[www.armscontrol.ru](http://www.armscontrol.ru)

# What is Unmanned Aerial Vehicle (UAV)?

UAV = Remotely Piloted Vehicle (RPV) = Drone

Unmanned Aerial Vehicle (UAV) - a powered, aerial vehicle that does not carry a human operator, uses aerodynamic forces to provide vehicle lift, can fly autonomously or be piloted remotely, can be expendable or recoverable, and can carry a lethal or non-lethal payload.

Ballistic or semi ballistic vehicles, artillery projectiles, cruise missiles are not considered unmanned aerial vehicles.

Non-state actors ≠ Terrorists



[www.armscontrol.ru](http://www.armscontrol.ru)

# UAV applications

- Military applications
  - Gathering intelligence
  - Armed attacks
  - Test targets
  - Electronic countermeasures
- Civilian applications
  - Law enforcement
  - Environmental monitoring
  - Agriculture

[www.armscontrol.ru](http://www.armscontrol.ru)

# Categories of UAVs

Category	Mini	Tactical	Strategic
Altitude	Low	Low to medium	Medium to high
Endurance	Short (about an hour)	Medium (up to several hours)	Long (ranges from hours to days)
Range	Close-range	Limited to line-of-sight (approximately 300 kilometers or less) (about 186 miles)	Long range
Example	Raven 	Shadow 	Global Hawk 

*Source: Nonproliferation. Agencies Could Improve Information Sharing and End-Use Monitoring on Unmanned Aerial Vehicle Exports, GAO Report, July 2012*

[www.armscontrol.ru](http://www.armscontrol.ru)

# Countries that acquired UAVs by December 2011



Algeria	Chile	Greece	Libya	Poland	Syria
Angola	China	Hungary	Lithuania	Republic of Korea	Taiwan <sup>a</sup>
Argentina	Colombia	India	Malaysia	Romania	Thailand
Australia	Croatia	Indonesia	Mexico	Russia	Trinidad and Tobago
Austria	Czech Republic	Iran	Morocco	Serbia	Tunisia
Azerbaijan	Denmark	Israel	Netherlands	Singapore	Turkey
Belarus	Egypt	Italy	New Zealand	Slovakia	Uganda
Belgium	Estonia	Ivory Coast	Nigeria	Slovenia	Ukraine
Botswana	Ethiopia	Japan	Norway	South Africa	United Arab Emirates
Brazil	Finland	Jordan	Pakistan	Spain	United Kingdom
Bulgaria	France	Kazakhstan	Panama	Sri Lanka	United States
Burundi	Georgia	Latvia	Peru	Sweden	
Canada	Germany	Lebanon	Philippines	Switzerland	

*Source:  
Nonproliferation.  
Agencies Could  
Improve Information  
Sharing and End-  
Use Monitoring on  
Unmanned Aerial  
Vehicle Exports,  
GAO Report, July  
2012*

# UAVs: some basic facts

- 76 countries acquired UAVs by December 2011
- Over 50 countries develop more than 900 UAV systems.
- Over the next 10 years annual spending on UAVs will increase by 73%, worldwide spending will total \$89 billion.
- Predicted U.S. share of spending: 62% on R&D, 52% of procurement costs.
- U.S. DOD's inventory of unmanned aircraft increased from 167 to nearly 7,500 from 2002 to 2010.
- US Federal Aviation Administration predicts that 30,000 drones will fill the nation's skies in less than 20 years.

# UAV as a tool of non-state actors

[www.armscontrol.ru](http://www.armscontrol.ru)



# Cases of use of UAVs by non-state actors

- Middle East: Hezbollah (intelligence missions, plans to use weaponized UAVs)
- Colombia: FARC
- Small criminal groups: drug traffic
- Individuals: Ferdaus case

# Ferdaus case



- A U.S. citizen Rezwan Ferdaus was arrested in September 2011.
- He planned to use F-4 Phantom and the F-86 Sabre, small-scale versions of military jets and pack five pounds of plastic explosives on each plane.
- The plan was to launch three such planes from a park near the Pentagon and Capitol and use GPS to direct them toward the buildings.

[www.armscontrol.ru](http://www.armscontrol.ru)

- There were a few attempts to use UAV technologies for terrorist purposes, none of them, fortunately, proved to be successful.
- UAVs may seem too exotic, demanding substantial efforts and costs compared with the methods terrorists already frequently use.
- It would be a mistake to overplay the threat of terrorist's UAVs. Certainly, it is not the top item in the threat priority list these days. Nevertheless, the threat exists and it will eventually grow.
- When we talk about threats from terrorist's UAVs, we need to think in broader terms. There is a fundamental problem. **Science and technology is developing so fast these days that a human society often fails to recognize how much the world has changed.** Appearance of new technologies and public services brings us more opportunities, but at the same time it makes us more vulnerable. Therefore, our society often misses a chance to react to emerging threats in a timely fashion.

# Threats posed by terrorist's UAVs

[www.armscontrol.ru](http://www.armscontrol.ru)

- The objects of terrorist attack and the most vulnerable targets are often places crowded by people: mass gatherings, highly populated city areas, public transportation at rush hour, etc. Terrorists usually pursue two goals: maximizing the number of victims and creating chaos and panic.
- A payload of UAV does not have to be large to produce significant damage. This is especially true with regard to weapons of mass destruction. Experts frequently note that an aerial vehicle is an ideal tool for delivering a biological or chemical weapon.

# Hypothetical tularemia attack on San Diego



A land-attack Silkworm variant, moving southward offshore, releases 120 kg of liquid BW agent. The colored bands represent the probability of infection (yellow >90 percent, green >50 percent, pink >10 percent).

*Source: Cruise Missile Proliferation: Threat, Policy and Defenses, by Dennis M. Gormley, Proliferation Roundtable, Carnegie Endowment for Peace, October 9, 1998*

[www.armscontrol.ru](http://www.armscontrol.ru)

# Consequences of BW attack

A scenario of BW attack assumes 2 pounds of weapons-grade anthrax being dropped from a height of 300 feet just upwind of a large US city containing 11.5 million people. 1.5 million of these 11.5 million become infected. Even under an aggressive response measures, model estimates that 123,000 people would die.

*Source: Lawrence M. Wein, D. L. Craft and E. H. Kaplan, "Emergency Response to Anthrax Attack," Proceedings of the National Academy of Sciences 100, No 7, 4346-4351, April 1, 2003*

# Consequences of a “dirty bomb” attack

A scenario of a “dirty” bomb attack assumes dissemination of 2 kg of plutonium (Pu-239) and 50 g of cesium (Cs-137) over San-Diego. The model predicts that 12,000 people would get various doses of radiation, 500 of those would get lethal doses. An area of the circle with the radius of 7-8 km would be contaminated.

*Source: M. Bakanov, Measures Conducted in the U.S. on Improving Defense Capabilities Against Cruise Missiles, "Foreign Military Review", N 10, 2002, pp. 30-35*



- Appreciable damage, though not so massive, could be caused by the most frequently used weapon of terrorists: a mix of explosives with small metal parts.
- Even a small explosive device, delivered by a UAV to a place crowded by people, could inflict much more damage than the same device on the belt of a suicide terrorist.

# Lessons of a terrorist attack in Moscow, July 5, 2003

- Two explosions killed 15 people and injured over 50 (later one more died in a hospital)
- Both “shaheed’s belts” consisted of explosives (equivalent to 0.5-1 kg TNT) mixed with small metal items (balls, screws, etc.)
- Composition of bombs was not optimal to create maximum energy release. In fact, one of two bombs did not work – its detonator only exploded. That bomb killed the terrorist herself only.
- Geometry of the explosions was not optimal as well. People, killed by the second explosion, effectively shielded those who were at a distance of few meters from the explosion.
- Terrorists failed to pass through guards to the crowded airfield. Panic was prevented.

**More casualties could have occurred, were the attacks from the air.**

# Why UAVs may seem attractive to non-state actors?

[www.armscontrol.ru](http://www.armscontrol.ru)

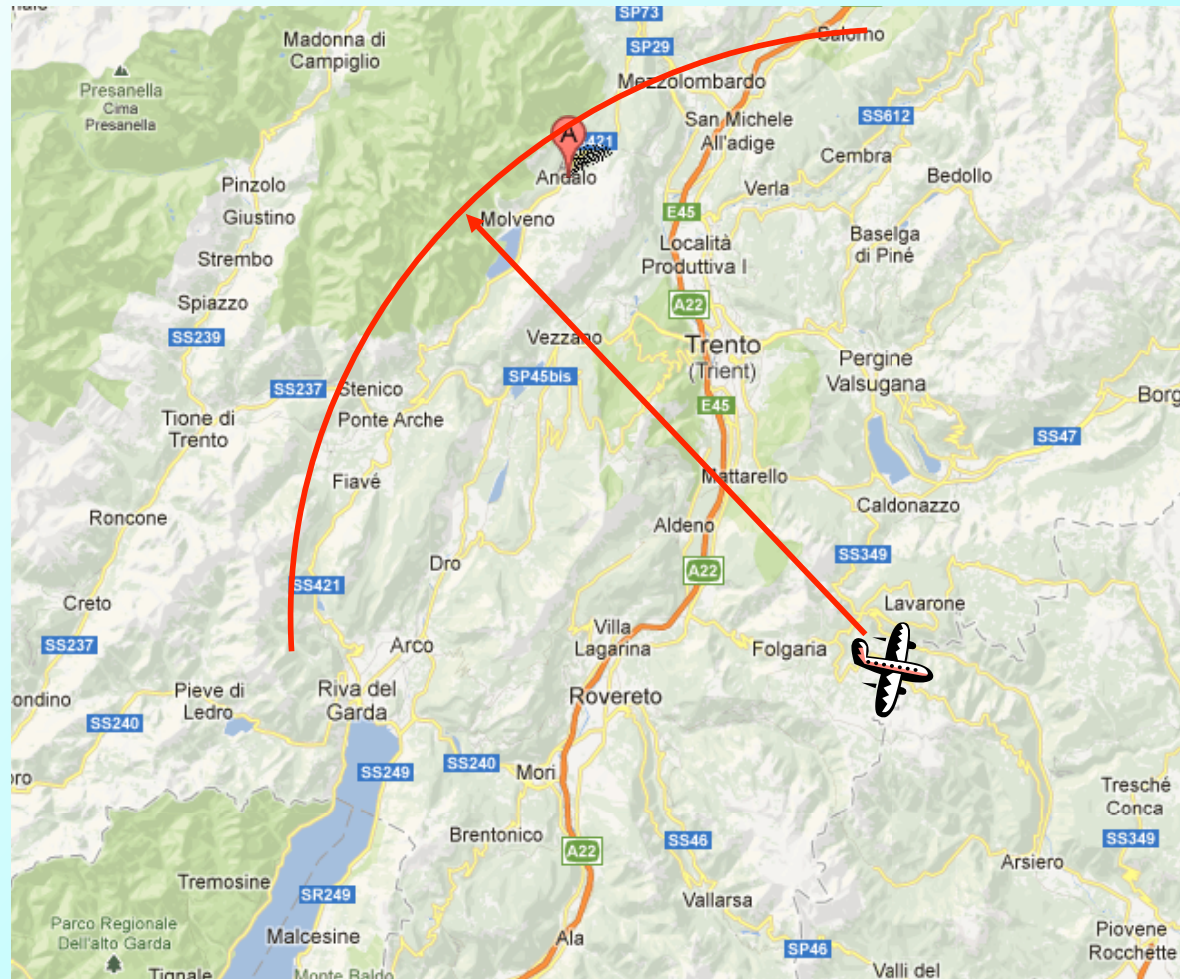

Short flight time. Small UAV launched from a distance of 25 km can reach its target less than within 15 minutes.

Poor effectiveness of existing air defenses against targets such as low-flying UAVs.

[www.armscontrol.ru](http://www.armscontrol.ru)



Covertness of attack preparation and flexibility in choice of a UAV launch site

[www.armscontrol.ru](http://www.armscontrol.ru)

# Advantages of UAVs for delivery of non-state actors's weapons

- High capability to “penetrate” into areas not accessible by land. It is almost impossible to prevent an attack once UAV is launched.
- Possibility of carrying out a wide-scale (area) attack, aimed at inflicting a maximum death rate on a population;
- Relative simplicity of assembling, covertness of preparation and carrying out an attack.
- Relative cost effectiveness of UAVs compared with ballistic missiles and manned airplanes;
- Possibility of achieving a strong psychological effect by scaring people and putting pressure on politicians.

# How terrorists could get an access to UAVs?

[www.armscontrol.ru](http://www.armscontrol.ru)

- UAVs for military application
- UAVs for civil use
- Conversion of private airplanes into UAVs
- **Assembly of UAVs on the basis of commercially available technologies and components**
- **Modification of commercially available radio-controlled model airplanes**



# Multilateral regimes controlling UAV exports

- MTCR restrictions:
  - Complete unmanned aerial vehicle systems (including cruise missile systems, target drones and reconnaissance drones) capable of delivering at least a 500 kg "payload" to a "range" of at least 300 km (Category I)
  - Complete unmanned aerial vehicle systems (including cruise missile systems, target drones and reconnaissance drones), capable of a "range" equal to or greater than 300 km (Category II)
  - Technologies and components specified in Category II list
- Wassenaar agreement: UAVs for military applications

# Mini-UAV as a potential tool of terrorists

- Modelers are currently able to assemble vehicles with capabilities that used to be achievable only by professional teams.
- Production-run accessories and separate parts such as engines, radio controls, servos, flight stabilization systems, and GPS receivers currently available commercially, and a wide spectrum of ready-to-fly aircraft kit models are on the market. Some models require experience in piloting, but other aircraft that are simple and stable in flight are produced specifically for beginners. Relatively simple designs that are stable in flight may be used.
- UAV control and delivery to a target is a more complex task, but this task is not beyond power of nonprofessionals. The most important element—preparation of an aerial vehicle for a terrorist attack, including assembly and tests—can be done legally, because such activity is not regulated or controlled.

[www.armscontrol.ru](http://www.armscontrol.ru)

# TAM-5 flight over Atlantic in 2003



Distance – 3020 km  
Flight time – 39 hr  
Take-off weight < 5 kg  
Fuel weight – 2.3 kg

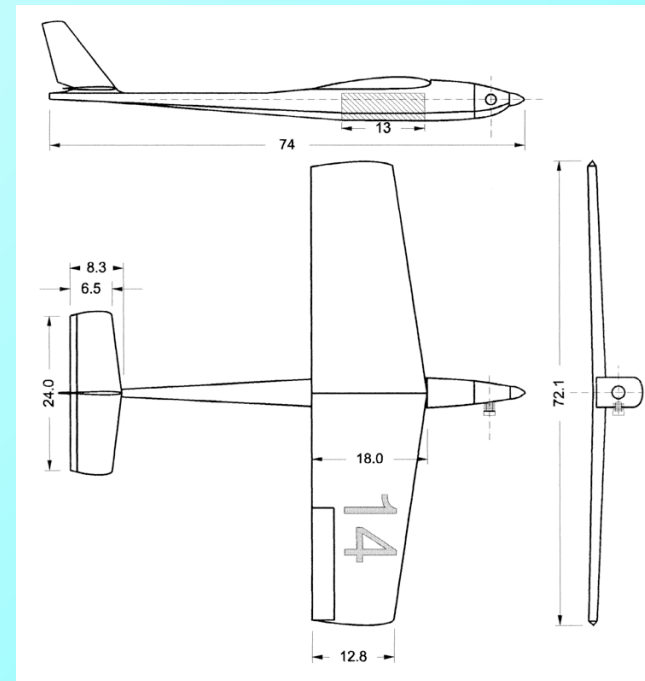
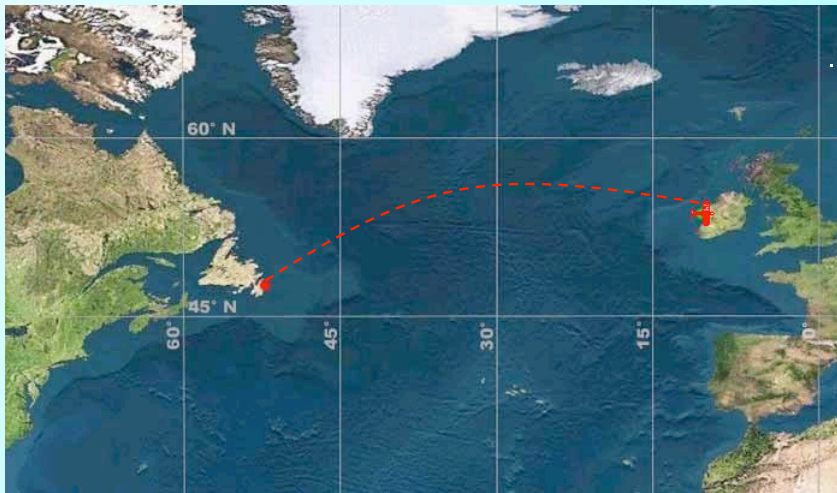

Possibility of achieving a long range and acceptable accuracy with relatively inexpensive and increasingly available technology

[www.armscontrol.ru](http://www.armscontrol.ru)

# Hypersonic planes built by model aircraft fans



Concord model

B-52 model



[www.armscontrol.ru](http://www.armscontrol.ru)

# Mini-UAV Composition, Technical Capabilities and Payload

[www.armscontrol.ru](http://www.armscontrol.ru)

# Composition of a small UAV

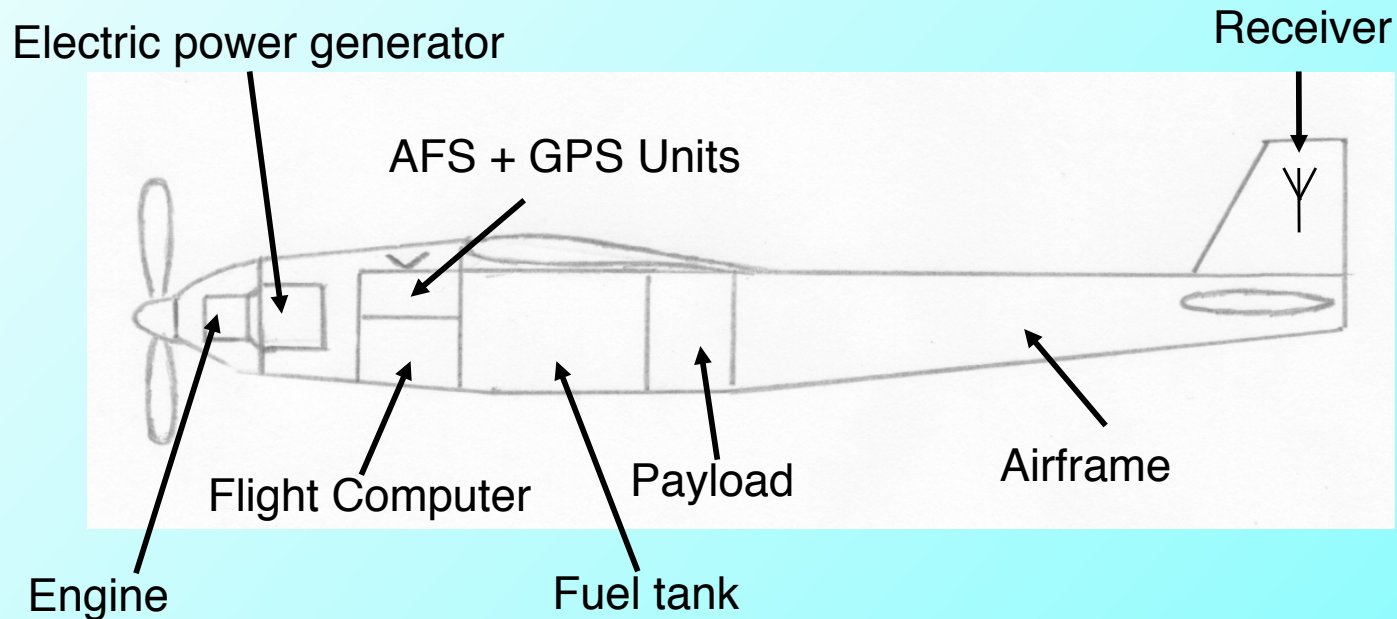

AFS – active flight stabilization  
GPS – Global Positioning System

[www.armscontrol.ru](http://www.armscontrol.ru)

## Weight fraction of components for a small UAV ( $m_{\text{tot}} = 5...60 \text{ kg}$ )

Composition	Relative weight
Airframe	$\sim 25\text{-}40\%$
Engine, $M_{\text{eng}}$	$\sim 10\text{-}15\%$
Fuel, $M_{\text{fuel}}$	$\sim 3\text{-}4\% \cdot T_{\text{fl}}$ (hours)
Electric energy generator	$< 10\%$
On-board electronics	$< 10\%$
Payload, $M_{\text{payload}}$	$< 50\%$

# Dimensions of computer and flight control elements

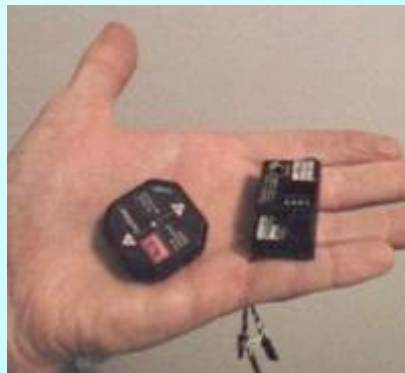
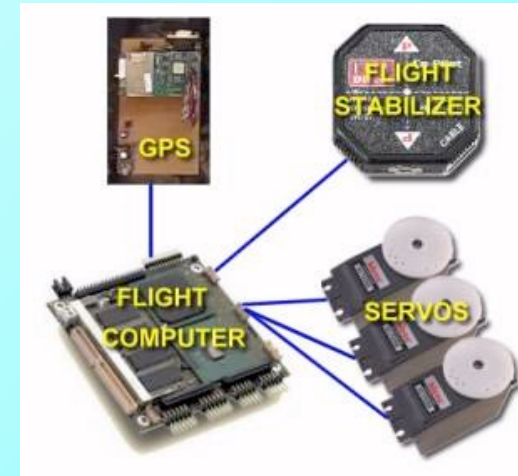
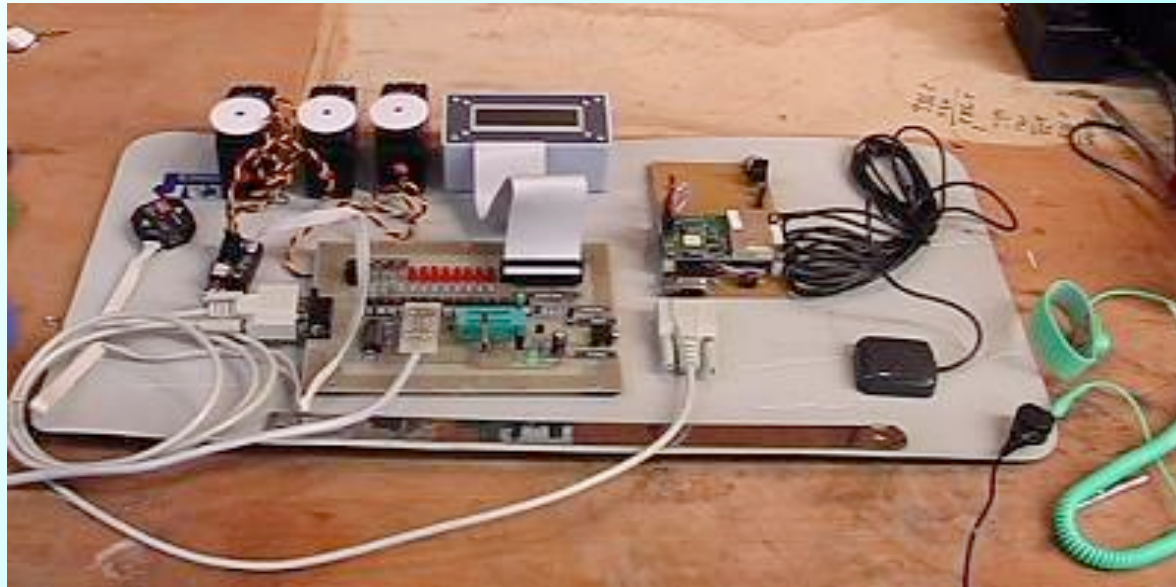

IR Flight Stabilizer



Source: <http://www.interestingprojects.com/cruisemissile/>

[www.armscontrol.ru](http://www.armscontrol.ru)



# Lanier Edge 540T 30% ATF airplane specifications



Wingspan	2.29 m
Wing Area	0.95 m <sup>2</sup>
Flying Weight	7.7 - 9.1 kg
Fuselage Length	2.13 m
Engine Weight	2.6 kg
Power @ 9000 rpm	~ 4.2 kWt

Models	Take-off mass, kg	Drag coefficient
Light	9	0.03
Heavy	12	0.03
Heavy, extra drag	12	0.04

[www.armscontrol.ru](http://www.armscontrol.ru)

# Maximum range vs speed

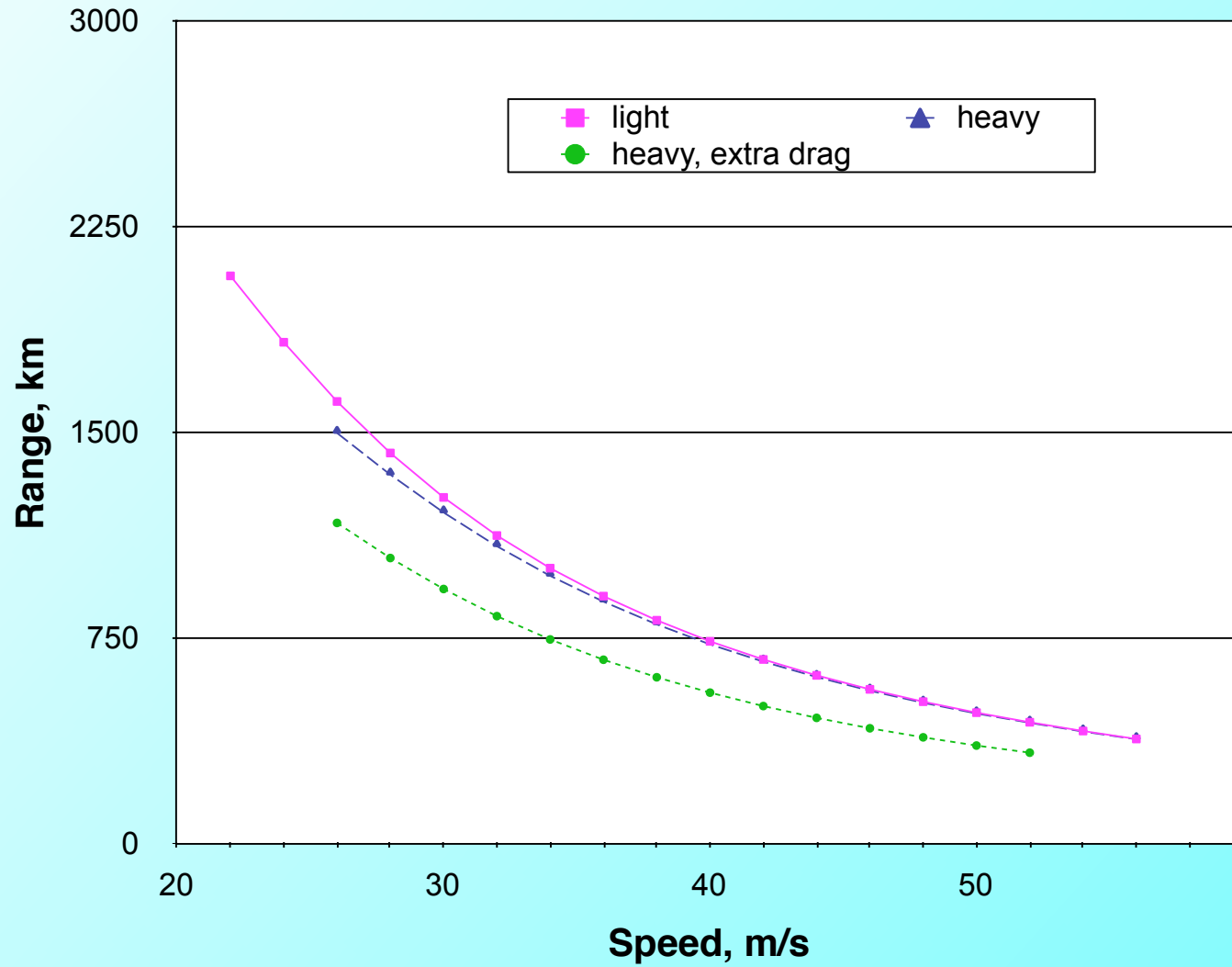

[www.armscontrol.ru](http://www.armscontrol.ru)

What needs to be done to prevent  
terrorist's mini-UAV attack in future?

[www.armscontrol.ru](http://www.armscontrol.ru)

# Why capabilities of existing air defenses against UAVs are limited?

- UAV flight to its target can be very short – no time to react
- Existing air defenses are designed to deal with large and fast targets. UAVs may have very small cross section.
- Some important targets can be defended.
- Cost of anti-air missile is much higher compared to the cost of a target
- Problem of “friendly fire”
  - Ukrainian S-200 SAM shut down Tu-154 airliner over the Black Sea instead of a target drone in 2001
  - Operation “Freedom of Iraq”: “Patriot” SAMs vs friendly aircraft 2:1
- Problem of coordination of military and civilian airspace monitoring efforts.

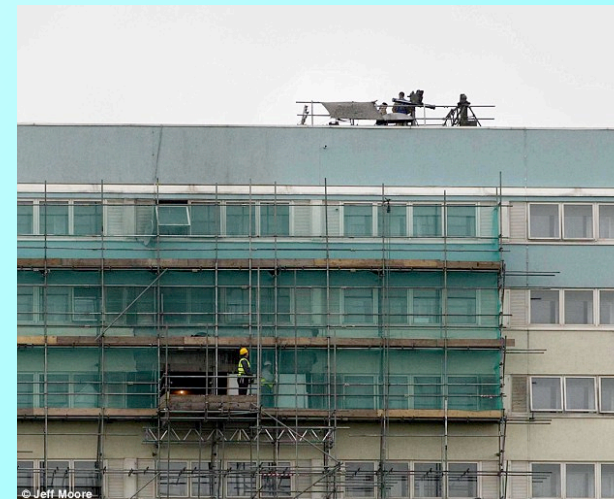

The UK Army placed a surface-to-air missile on top the Fred Wigg tower block in Waltham Forest, London as part of a series of security tests for the 2012 Olympics

*Source: Stephanie Condron and Chritopher Leake, Poison drones carrying biological weapon are new Olympic threat, warns Colonel in charge of keeping London calm, Daily Mail, May 5, 2012)*

[www.armscontrol.ru](http://www.armscontrol.ru)

# Suggested measures to deal with terrorist's UAVs

- Attempts to limit the spread of commercially available model airplanes or their components is at least a questionable option, if not a viable one.
- One of the strong measures to prevent terrorist's UAV attacks could be increasing public awareness of the existing threat.

**Threat of Terrorism Using  
Unmanned Aerial Vehicles:**

**Technical Aspects**

By Eugene Miasnikov

Center for Arms Control, Energy and Environmental Studies  
Moscow Institute of Physics and Technology  
2005

For the details, please, visit: <http://www.armscontrol.ru/UAV/report.htm>

[www.armscontrol.ru](http://www.armscontrol.ru)